

## RESEARCH OF THE PROCESS OF POTATO WASHING BY MEANS OF VIBRATION

Antropova Lyudmila, \*Gladkaya Alla, Datkov Vladimir

National University of Economics and Trade – Donetsk, Ukraine

\*Gladkaya Alla, gladkaya\_alla@mail.ru

**Abstract:** Information on the effects of vibration, as an effective means of mechanical action on potato tubers in the process of washing, the effects of shape and vibration parameters of a washing machine's working chamber on the effectiveness of washing process, is presented. Designs of vibrating washing machines of continuous action have been proposed.

**Keywords:** vibration, the process of washing, and vegetables.

Various designs of continuous action machines are used for washing potatoes in the food industry enterprises and in specialized shops of the catering enterprises. [1]. Analysis of their technical characteristics showed that vibration machines are characterized by high productivity and quality of washing, low power consumption and small size external dimensions. Application of vibration is one of the priority directions representations for intensification of technological processes [2].

The purpose of the work is both theoretical and experimental studies of the process of washing potatoes with the development of continuous action machines.

At DonNUET Department of food production equipment, the authors developed a stand for studying the process of washing with two working interchangeable chambers: a cylindrical and W - shaped. Unbalance vibration exciters with eccentric weights are installed in the chambers, which allowed changing the amplitude of the chambers' vibration oscillation. Frequency of the chambers' oscillation was adjusted by changing rotational velocity of the motor shaft.

To achieve the set goal, the following problems have been solved:

- Analytical determination of the velocity of movement and strength of the interaction between the tubers in the process of washing;
- Determination of the shape the trajectory of the working chamber, the nature of tubers movement and the quality of washing;
- Development of the machine designs for continuous washing of potatoes.

As it was shown by preliminary studies, the movement of tubers is circulating in nature and determined by the average velocity of vibration displacement and the forces of interaction between tubers. These forces depend on the mode of oscillations, trajectory, frequency and amplitude of the working chamber.

Under the influence of vibrational oscillation, the tubers slide on the surface of chamber, throw up and collide. Interaction of tubers with the vibrating surface is taken into account by using the coefficients:

- Recovery rate of  $R$ ;
- Instantaneous friction  $\zeta$ .

Viscous friction of tubers moving in the cramped conditions of the working chamber of vibrating machinery is taken into consideration by the viscous friction coefficient  $K$ .

Let us represent the movement of tubers in the working chamber in the form of a chain of discrete masses  $m$  located along the surface of the chamber cross-section and interconnected by elastic elements of the stiffness.

The discrete masses  $m$  are effected by the forces of:

- gravity  $P_i=mg$ ;

- inelastic viscous resistance  $m\dot{\underline{x}}$  и  $m\dot{\underline{y}}$ ;

- interaction between tubers  $T_{i-1,i}, T_i$ ;

- static pressure  $P$ .

According to the method of direct separation of motions [3-5], movement of tubers in the chamber consist of small fast movements that multiple of the period of forced oscillations, and slow-moving circulation presented in the form

$$m\dot{V}_i + mkV_i = -P_i \sin \beta_i + T_{i-1,i} - T_{i,i+1} - W_i(V_i) \quad (1)$$

where:  $m$  – mass of tubers;

$V_i, \dot{V}_i$  – Velocity and acceleration  $i$  – of that tuber;

$W_i(V_i)$  – vibrational force acting on the tuber;

$T_{i-1,i}, T_{i,i+1}$  – forces of interaction between the tubers;

$\beta_i$  – angle of the surface area of the working chamber at the place of location  $i$  – of that tuber;

$P$  – static pressure.

For the analytical determination of the velocity of movement and forces of interaction between the tubers let us represented a tuber in the form of a material point moving on a rough inclined surface.

In the relative motion the material point is affected by the forces of:

• inertia  $m\ddot{\xi}$  и  $m\ddot{\eta}$ ;

• the normal reaction  $N$  of pressure on the plane of the tubers;

• gravity  $P$ ;

• friction  $F$ .

Having obtained the equations describing the vertical and horizontal movement of tubers in the mode of continuous throwing up, as a result of their transformations, we obtain the average velocity of the circulation movement of tubers in the mode of continuous throwing up.

$$V_i = V_i^* + \frac{1}{V_i} \quad (2)$$

where:  $V_i^*$  – the average velocity  $i$  – of that tuber in the absence of interaction forces;

$v_i$  – coefficient of weighting that takes into account non-uniformity of velocity on certain sections.

Let us represent the average velocity  $V_i^*$  in the form

$$V_i^* = a \cdot \omega \cdot b_i' - \frac{1}{v_i} \cdot g_i \cdot \sin \beta_i \quad (3)$$

where:

$$b_i' = \frac{A}{1 + \left(\frac{k}{\omega}\right)^2} \cdot \frac{1 \cdot e^{-\kappa TP}}{\kappa TP} \cdot (c_i - 1) \cdot \left(\frac{k}{\omega} \cdot \cos \varphi_0' + \sin \varphi_0'\right)$$

$$v_i = \frac{k \cdot \kappa TP}{\kappa TP + (c_i' - 1) \cdot (1 - e^{-\kappa TP})};$$

Equations (1) and (3) constitute with considering the boundary conditions  $T_{0,1} = T_{n,n+1} = 0$  a closed system from  $n$  co-relations

$$g_i \sin \beta_i = t_{i+1,i} - t_{i,i+1} - v_i(v_i - a\omega b_i) \quad (4)$$

which have solutions:

$$V_c = \frac{\sum_{i=1}^n v_i \cdot V_i^*}{\sum_{i=1}^n v_i} \quad (5)$$

$$T_{i-1,i} = m \sum_{j=1}^{i-1} (V_j^* - V_c) \cdot v_j$$

where:  $V_c$  – the average velocity of tubers motion on the vibrating surface;

$T_{i-1,i}$  - forces of interaction between the tubers.

LEDs, which were fixed in a special enclosure at the end of the chamber wall, were used to determine the mode of vibration of the working chamber. The luminous flux from the LEDs passed through the hole in the casing with the diameter of 0.1 mm [6].

At the chamber vibrations LEDs traced the trajectory of the calculation points. The experiment was performed at amplitudes of 0.001-0.005 m and circular frequency of the vibrator 90-140 sec<sup>-1</sup>.

The studies have shown that the mass center of the working chamber traces a circular trajectory in the plane of perpendicular axis of the vibration exciter. Other points of

the working chamber move along a closed curve, an ellipse, and angles of the ellipses at different points are different.

High-speed filming has confirmed that the prevailing character of the tubers movement is circulating in the plane of perpendicular axis of the vibration exciter.

Removal of contaminants from the surfaces of tubers occurs due to circulation movement and effects, repetitive collisions of tubers that facilitate a uniform potatoes processing. Feed of water from a sprinkler provides continuous removal of contaminants.

The quality of washing potatoes was assessed as a correlation between the current ratio of tubers contamination and the initial one.

Increasing the circular frequency of oscillations of the working chamber up to  $140 \text{ sec}^{-1}$  provides high quality washing, and the velocity of tubers reaches  $2.5 * 10^{-2} \text{ m/ sec}$ , and the force of interaction between the tubers amounts to 2.7 H, whereas the amplitude of oscillations and the time of processing insignificantly affect the process.

On the basis of studies, the following designs of vibrating washing machines of continuous action were offered (Figure 1 and Figure 2).

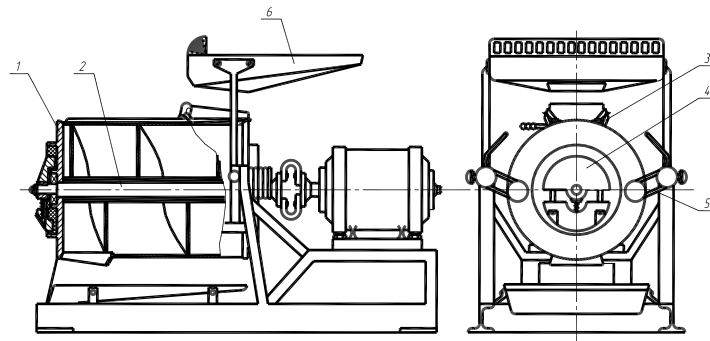

**Fig1.** Vibration washing machine with a cylindrical working chamber. 1 –working chamber, 2 - unbalanced vibration exciters, 3 - irrigation; 4 - unbalance, 5 - elastic suspension.

A fixed pipe is welded in the machine on the horizontal axis of the chamber, the unbalanced vibration-exciter 2 connected through a flexible coupling to the motor machine is located in the fixed pipe (Fig. 1). Two automatically controlled imbalances are fixed in the exciters 4. Unbalanced weights are held by springs in a position where their eccentricity is negligible and, therefore, the disturbing force at the start and stop of the machine is small. This allows reducing loads on the foundation at the start and stop of the machine.

A fixed single-start screw welded to the central tube, creates a screw-shaped channel for moving tubers, and also increases the surface of vibration effects on them.

The outer cylinder, which is the casing of the working chamber, is attached to the frame on the ring elastic elements 5, perceiving the vibratory oscillations.

In the process of washing the tubers are fed into the hopper 6. Their movement along the chamber occurs due to the continuous vibration of the casing and intakes of new portions of the product. Removal of contaminants occurs due to intense friction of tubers on each other, as well as on the walls of chamber and the screw channel. Contaminants are washed away with water fed from from the sprinkler3.

The machine (Fig. 2) with a W-shaped working chamber 1, has a loading hopper 2 and an unloading outlet 3. The chamber is firmly suspended on elastic cylindrical springs 4,

which are rested on the frame 5. An unbalanced vibration-exciter with self-regulatory imbalance is used as a drive 6 [7].

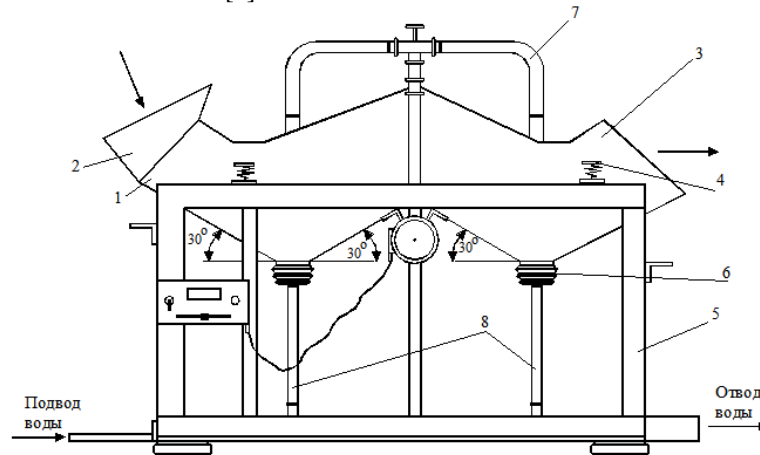

**Fig. 2.** Machine with a W-shaped working chamber: 1 –working chamber 2, 3 loading hopper and unloading outlet 4 - springs, 5 –frame 6 - vibration exciter, 7 - sprinklers, 8 - drains for the dirty water.

The working chamber with a cross-section in the form of a circle is divided into two divisions, in which the processes of soaking and washing tubers are executed consistently. For this purpose, two sprinkles are provided 7, 8, and two drains to drain the dirty water.

Location of the vibration-exciter below the mass center of the chamber generates its vibrations along the elliptical trace. The direction of vibration-exciter rotation is coincided with the movement of tubers, which are moved by the combined effect of vibration and backing of the potato.

When moving, the tubers overcome two ascents and descents at the angle of  $30^\circ$ , which is determined by the shape of a working chamber.

Presence of unbalanced exciter with the adjustable eccentricity allows changing the amplitude of vibration oscillations. Stiffness of springs and t vibration frequency of the working chamber can adjust the velocity of tubers movement and modes of washing potatoes.

### Conclusions.

1. Intensity of the washing process is determined by velocity of and forces of the tubers interaction.
2. Movement of tubers in the vibrating drum washing machine is of circulating nature in the plane of perpendicular axis of the vibration exciter.
3. A mode with continuous throwing up of tubers was approved as the rational mode of vibration displacement of potatoes in the washing process.
4. Theoretical dependencies on determination of velocity and forces of thee tubers interaction in the process of washing can be used to develop a new vibration machines.

**Literature**

1. Гончаренко К. М. Технологическое обладнання консервних та овочепереробних виробництв /К.М. Гончаренко, В.В.Дуб, В.В.Гончаренко – К.:Вища освіта, 2007. – 303с.
2. Гончаревич И.Ф. Вибрационная техника в пищевой промышленности /И.Ф. Гончаревич, Н.Б. Урьев, М.А.Талесник. – М.: Колос, 1977. – 276с.
3. Блехман И. И. Метод прямого разделения движений в задачах о действии вибрации на линейные механические системы / И. И. Блехман //Изв. АН. СССР. Механика твердого тела. – 1976. – № 6. С. 13–27.
4. Лавандел Э. Э. Система гипотез в технологических расчетах по вибрационному перемещению /Э.Э. Лавандел //Вопросы динамики и прочности. – Рига, 1971. – Вып.21. – С. 5–10.
5. Блехман И.И. Вибрационное перемещение /И.И.Блехман, Г.Ю.Джанелидзе. – М.: Наука, 1964. – 328 с.
6. Антропова Л.Н. Применение вибрации для мойки овощей на предприятиях ресторанного хозяйства /Л.Н.Антропова, А.Д.Гладкая, В.П.Датьков //Вісник СУНУ ім.В.Даля. – Луганськ, 2010. - №1[143], Частина1 – С.7-12.
7. Антропова Л.Н. Совершенствование процесса мойки картофеля с помощью вибрации/ Л.Н. Антропова, А.Д. Гладкая, В.П. Датьков//Тезисы докладов V Международной научно – технической конференции «Техника и технология пищевых производств» 05.2005. Могилев. С.180 – 181