



Ilie Nuca, Adrian Țurcanu

## Modernization of the Grinding Electromechanical Drive System of the Automated Coffee Machine

The paper refers to espresso coffee machines high quality and some possibilities to increase the level of automation and productivity. Existing machines require manual adjustment of coffee grinder depending on the quality of coffee beans. To eliminate this flaw has been developed and implemented an adjustable electromechanical system with DC servomotor and numerical control of coffee grinder. Computer simulation results demonstrate the functionality of the proposed electromechanical drive system of the coffee grinder

Keywords: coffee machines, electromechanical system, DC servomotor, numerical control

### 1. Introduction

Coffee maker is one appliance the can be seen nearly in every home and office, as society has embraced coffee as a new human necessity. Coffee machines [1], [2], [3] have begun to become incredibly complex due to the technological development and the accessibility of automating devices. The increased level of sophistication of the coffee machine provides a better coffee brewing, and as a result, a higher quality beverages for a smaller cost.

Purpose of the work consists in developing an electromechanical automated adjustment system of the grinder to the quality of coffee beans.

### 2. Coffee extraction methods in modern coffee machines

There are many methods for brewing a fine cup of coffee and no single technique is right for everyone. The most popular variation of the pressurized percolation brewing is the coffee called espresso. After lots of experimentation, Luigi Bezzera came up to some exact figures for extracting the perfect shot of espresso.

These technical parameters that have been outlined by the Italian Espresso National Institute [1] are given in the table 1.

Table 1. The technical parameters for making the Certified Italian Espresso

ELEMENT	PARAMETER
Portion of ground coffee	7.0 g $\pm$ 0.5
Exit temperature of water	90°C $\pm$ 3°C
Temperature in cup	67°C $\pm$ 3°C
Entry water pressure	9 bar $\pm$ 1
Percolation time	25 sec. $\pm$ 5
Volume in cup (including froth)	30 ml $\pm$ 2.5

Taking these parameters and the technical possibilities of modern days into consideration there can be outlined three types of extracting technics:

1. Extraction with non-pressurized portafilter – this type of portafilters have no outlet valve inside them that can control the appropriate 9 bar pressure for extracting the espresso in wright conditions. The appropriate adjustments are made with the fineness of the grounded coffee.
  2. Extraction with pressurized portafilter – these portafilters have a system inside them in the form of an outlet valve that controls the pressure inside and keep the 9 bar no matter the fineness of the ground coffee.
  3. Extraction with brewing unit. In 1986 SAECO Company introduced the brewing unit for the first time [2]. The unit gives the possibility to automate the brewing process completely. It makes four very important actions while brewing:
    - a. It receives the grinded coffee from the dozer,
    - b. Compresses the coffee into the brewing capsule with the appropriate force,
    - c. Runs the 92°C water through the coffee capsule with the 9 bar pressure controlled by the outlet valve that is incorporate in the unit.
    - d. Throws the used coffee into the dregs drawer.
3. The structure of the electromechanical system of the super-automated class of coffee machines

Historically, the espresso brewing is a product of the Italian technical revolution of the 19<sup>th</sup> and early 20<sup>th</sup> century. The technology changed a lot from those times ending with one of the most sophisticated class of coffee makers nower days and this is the super-automated machines that have a fully automated process that starts with grinding the beans and finishies with proper extraction of espresso. In the fig. 1 the scheme of such an electromechanical system is represented.

As there was mentioned earlier, the hydraulic system must ensure the necessary water and steam characteristics for the proper function. The structure of the system consists of boiler J for brewing and hot water dispensing, and the pipe hea-

ter for steam. The necessary pressure of the water is provided by an electromagnetic pump and the right quantity of the water is measured by a turbine flow meter.

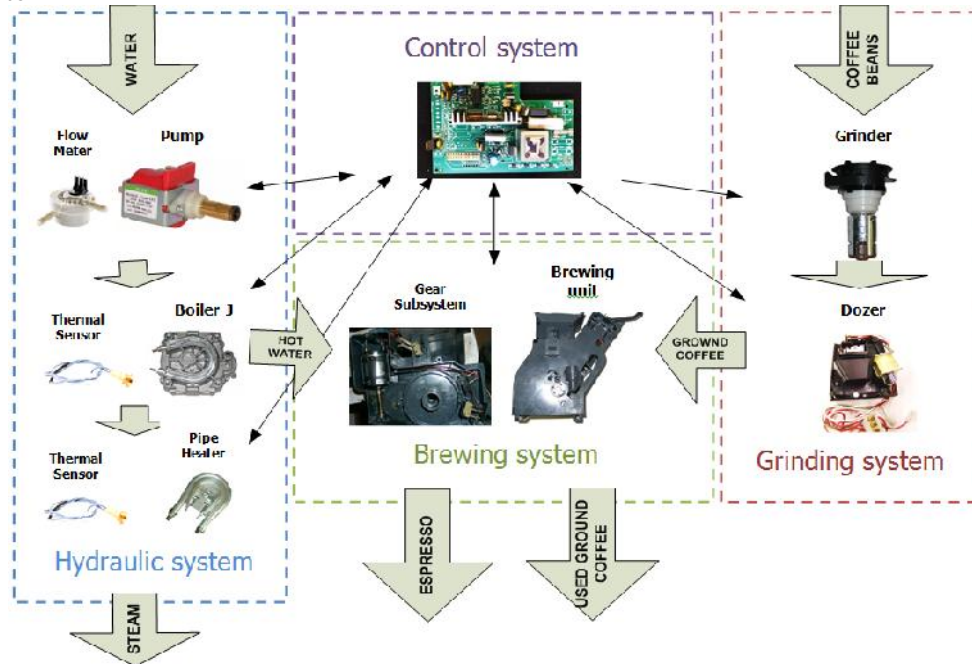

Figure 1. The scheme of the electromechanical super-automated system of the SAECO ROYAL series

By means of the grinding system the coffee beans are grinded and the necessary amount of ground coffee is measured and thrown into the brewing unit and taking into the consideration the manipulations that are necessary for these actions this system consists of the following components:

The hydraulic system [3] must ensure the necessary water and steam characteristics for the machine proper function. The structure of the system is given in the fig. 2 where the both boilers of the system can be seen with boiler J for the hot water and for brewing and hot water dispensing, and the pipe heater for heating the hot water from the boiler J to steam. The necessary pressure of the water is provided by an electromagnetic pump and the right quantity of the water is measured by a turbine flow meter connected in the low pressure part of the pipe system.

- o Dozer – the coffee quantity for the every coffee process is portioned (dosed) in the dozer chamber where a higher dose results in a stronger and more concentrated coffee, and a lower dose results in a weaker one. The dosing process is controlled via a micro switch which is activated when the dosing chamber is fully

pressed with coffee by the grinder, and the micro switch transmits to the CPU the signal to turn the grinding motor OFF.

o Grinder – is the electrical burr grind that consists of two revolving, conical elements with upper and lower grinding disc. The grind level is set by adjusting the height of the upper grinding disc by means of the screw thread. The grinder has three main components:

- Grinding discs;
- Gearbox that reduces the grinding motor rotations with 40:1;
- DC current, 240V grinding motor.

The brewing system performs a number of very important actions with the grounded coffee that comes from the grinding system and in order to do these actions the system contains a set of subsystems that are listed below:

- a. Brewing unit – the extraction with a brewing unit is described in the section 2.
- b. Gear subsystem – this subsystem puts to motion the brewing unit. The gear motor is a reversible direct current motor and is controlled by the CPU at approximately 30 – 35 V.

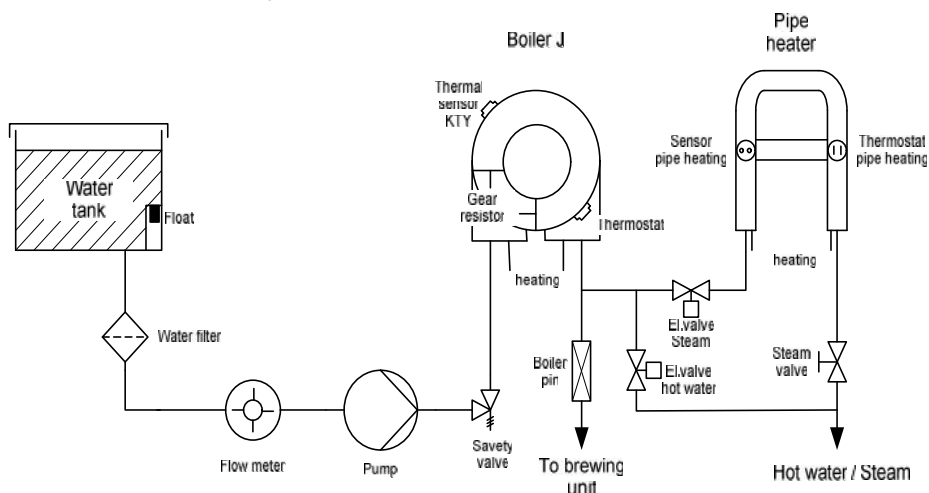

Figure 2. SAECO RAPID STEAM hydraulic heating system [3]

The whole system of the present coffee machine is controlled by a numerical control system that consists of two electronic boards and a display with a set of buttons for controlling the system. The first board is the power electronic board on which the power elements of the coffee machine are connected. The second board is for processing the signals that come from sensors and transducers. The central processing unit (CPU) gathers all the incoming signals, analyses them and reacts according to the program installed on it.

#### 4. Modernization of the grinder's adjustment system of the coffee machine

As it was outlined in the previous section, there are some very exact characteristics and conditions in which the perfect espresso extraction can take place and these specifications have been exactly determined by the Espresso National Institute of Italy (see table 1). The components and the control system of the present automated coffee machine can provide the necessary quality of the water temperature, pressure, flow rate and the duration of the percolation process, but the grinding process remains automatically nonadjustable and it can be concluded that the system is not fully automated and that the need of a technical operator would be necessary every time when the quality of the coffee beans would change. The quality of the coffee bean is determined by a number of factors that have an influence on the grinding process, and consequently, on the quality of the extracted beverage. These factors are very numerous, diverse and of different nature and some of them are:

- The grade of coffee
- The humidity level
- The over drying

As it can be concluded, the quality of the coffee beans has a big influence on the level and the duration of the grinding process and in order to modernize the grinder adjustment system it is necessary to understand the influence of coffee bean with different qualities on the rest of system's components which are presented in the following list:

➤ Pump – the grinding level influences the hydraulic system and especially the flow rate of the pump and the necessary pressure for the water to pass through the packed grounded coffee in the brewing unit chamber. The grounded coffee can be characterized as a substance that resists to the water that is passing through it and this resistance varies along with the variation of the fraction of the grounded coffee. This variation is proportional to the fraction of the ground coffee, thus the bigger the fraction the higher the flow rate and lower the necessary pressure for the passing water. After the measurement performed on the pump during the data collection, it was possible to construct the flow rate and current dependences in terms of coffee fraction diagrams that are presented in the fig. 3 where the coffee fraction has been noted from 0 (the finest grinding) to 4 (the most coarser grinding), with the needed fraction noted with 2.

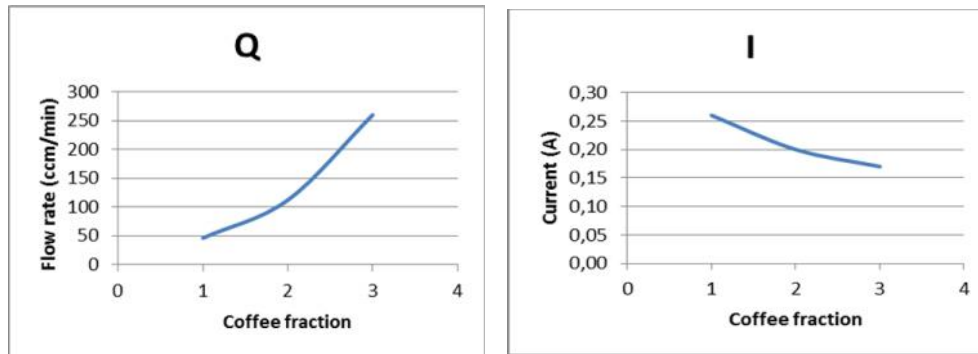

Figure 3. Flow rate and current in terms of coffee fraction diagrams

➤ Grinding – the coffee fraction size influences the duration of grinding time. The smaller the fraction of the ground coffee the longer the grinding time.

For the performance of an automated adjustment system it is necessary to collect some measurement on one of the system's components in order to detect the necessity of the adjustment operations, and based on the component to perform the needed manipulations. Taking into the consideration the influences of the coffee fraction size enumerated above, the only parameter that differs with the same dependency no matter the coffee grade selection, or the quality of it, is the flow rate of the water during the brewing process. This control can be performed directly, by controlling the actual flow rate with the hydraulic system's flow meter, or indirectly by controlling the current that is passing through the pump. The easiest and the most exact solution would be the direct control of the flow rate.

In order to adjust the grinding discs and to move the upper disc up for a coarser grinding and down for a finer grinding it is necessary to move the adjustment ring on the grinder (fig. 4) in a clockwise direction for a finer grind and anticlockwise for a coarser grind. The actual adjustment performed by a technical operator has several steps that are enumerated in the following list:

1. Makes the first extraction in order to check the actual necessity in adjusting the grinder.
2. Turns the adjustment ring for just a couple of degrees in a clockwise direction for a finer grinding, or anticlockwise for a coarser grinding. The important fact is that the actual turning action of the ring has to be performed with the moving grinding in order not to block the grinder and, as a result to burn the motor.

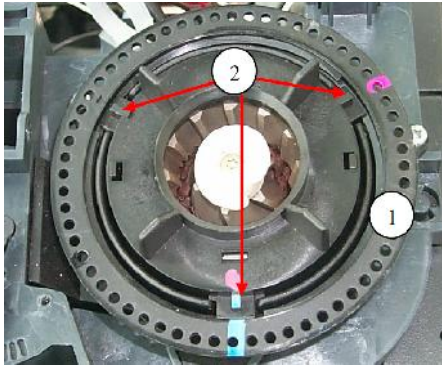

Figure 4. SAECO grinder  
 1 – adjustment ring  
 2 – three fitting lugs of the upper grinding disc

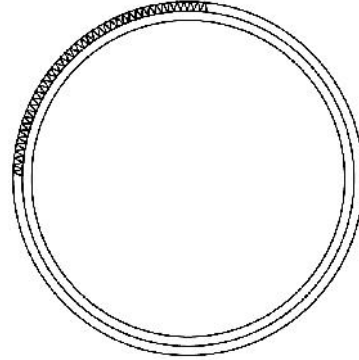

Figure 5. The cogwheel of the automated adjustment system

3. Makes three consequently extractions in order to check the new adjustment. The peculiarity of the adjustment process is that the actual new adjustment comes only after a second or a third extraction, due to the fact that the mill of the grinder is filled with ground coffee grinded with the old adjustments.

4. If the further adjustments are necessary the steps 2 and 3 are repeated again and these actions can be repeated as many times as necessary.

Taking into the consideration the enumerated steps and the fact that this is the only possible procedure for the adjustment of the grinding system, the automated adjustment system has to repeat them and for that some modifications has to be done on the grinding system so that it could repeat them. In the fig. 6 the structural scheme of the grinding system is represented where the proposed adjustment system is showed.

The necessary modifications are:

1. A cogwheel has to be mounted on the grinder's adjustment ring in order to give the automated adjustment system the possibility to turn the adjustment ring (fig.5). Considering the dimensions of the adjustment ring the total number of teeth on the cog ring would be 180 with 1 tooth for every  $2^\circ$ .

2. A servomotor has to be added in the adjustment system that would provide the necessary movement of the adjustment ring. Considering the fact that the ring needs to be moved in both directions, it is decided to choose a DC servomotor

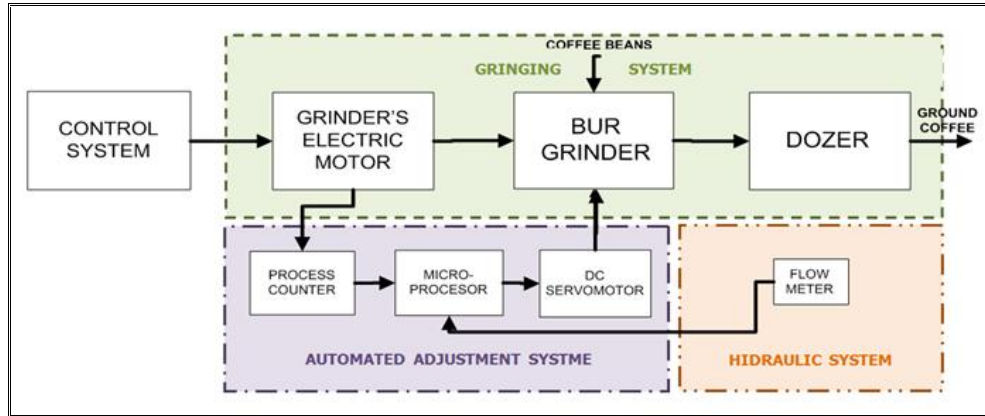

Figure 6. The scheme of the electromechanical system of the grinder

which provides an easy way to change the rotation of it by changing the polarity of the connection. In order to dimension the parameters of the necessary DC motor a number of calculations are required

$t_{ad} = 1\text{sec}$  - the time of a single adjustment

$D_{ar} = 95\text{mm}$  - the diameter of the adjustment ring;

$D_{sh} = 38\text{mm}$  - the diameter of the cogwheel on the shaft of the motor;

$L_b \leq 10\text{mm}$  - the length of a single adjustment;

$L_{ar} = D_{ar} \cdot f = 95 \cdot f = 298,3\text{mm}$  - length of the adjustment ring;

$V_{ad} = \frac{L_b \cdot 60}{t_{ad}} = \frac{10 \cdot 60}{3} = 200\text{mm}/\text{min}$  - velocity of the adjustment movement;

$L_{sh} = D_{sh} \cdot f = 38 \cdot 3,14 = 119,4\text{mm}$  (1)

$\%_c = \frac{V_{ad}}{L_{sh}} = \frac{200}{119,4} = 1,68\text{rot}/\text{min}$  (2)

Based on the calculations above, a reversible servo DC motor of the type – 145 is chosen and is represented in the (fig. 7) along with the technical parameters of it [4].

The selected servo motor provides the necessary velocity for the movement of the ring and the adjusting time would be 1 sec.

3. Considering the fact that the reprogramming of the SAECO ROYAL DIGITAL PLUS control system can be done with the SAECO programmer only, and that the





$U_n = 27 \text{ V.DC}$	$n_r = 145 \text{ rot/min}$
$I_n = 0,6 \text{ A}$	$\eta = 25\%$
$P_{n,n} = 2,45 \text{ W}$	$M_n = 1,69 \text{ kg/cm}$

Figure 7. DC servo motor of the type – 145

subject of the present work is just proposing the modernization of the electromechanical system a microprocessor (MP) is necessary to be added to the automated adjustment system and the whole system will function independently with the monitoring of the grinder function and for that a relay as a process counter will be added as well that will send a signal to the MP. In the fig. 8 the programming scheme of the MP is represented.

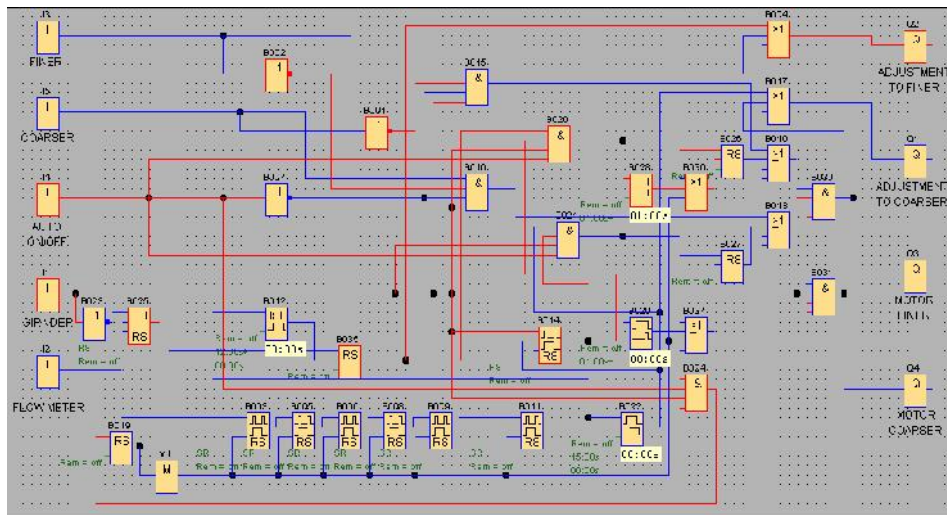

Figure 8. The programming of the microprocessor

#### 4. MATLAB simulation of the grinder adjustment system

Taking into the consideration the fact that the simulation software gives us a good possibility to analyze the performed calculations without spending any money for the actual components it was decided to simulate the work of the servomotor

with all the reducers in order to check the system functioning during the adjustment movements. For this simulation the MATLAB SIMULINK software will be used with its SimPowerSystems library pack.

- The initial parameter of the chosen servomotor provided by the manufacturer:
  - 145 - Motor code;  $P_n = 2,45W$  - Rated power;
  - $i = 10:1$  - Gear ratio;  $\gamma = 25\%$  - Efficiency;
  - $U_n = 27Vdc$  - Nominal voltage;  $R_a = 16,7\Omega; L_a = 1H$ ;
  - $n_r = 145rot / min$  - Nominal speed after reduction;  $R_f = 136,5\Omega; L_f = 70H$ ; - Armature and field parameters;
  - $I_n = 0,6A$  - Rated current;

➤ Calculated parameters of the DC motor

- Nominal angular rotor speed, rad/sec

$$\%_{\omega_n} = \frac{2f \cdot n_n \cdot i}{60} = \frac{2f \cdot 145 \cdot 10}{60} = 151,8 rad / s \quad (3)$$

- Nominal torque, N\*m

$$M_n = \frac{P_n}{\%_{\omega_n}} = \frac{2,45}{151,8} = 0,0161 N \cdot m \quad (4)$$

To study the operation of modernized coffee grinder was developed the mathematical model of electromechanical systems in accordance with the corresponding relations of the components [5]. The Simulink model (fig.9) include blocks of the DC motor, Speed Reducer and the cogwheel to the adjustment ring with the specific parameters.

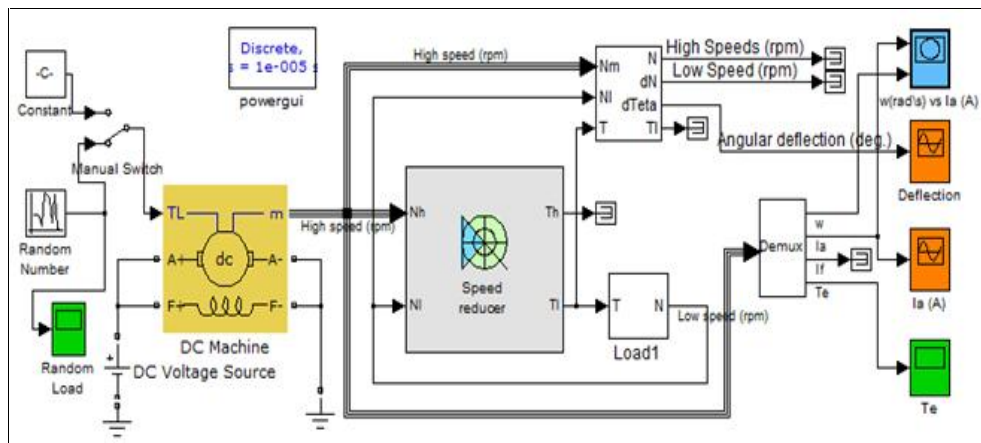

Figure 9. Adjustment system DC motor speed reducer simulation

The simulation was performed with two different load: with the constant load and with the random load that would represent the different quality of coffee beans during the grinding process. After the performed simulation the results of the modeling are displayed by the scope of the present model. The scope representations are given in the fig. 10 for the constant load on the grinder and fig. 11 with the representation of the results for the random load on the. The simulation showed that even with random load on the grinder the angular deflection within 1-2 seconds is quite enough for the adjustment process.

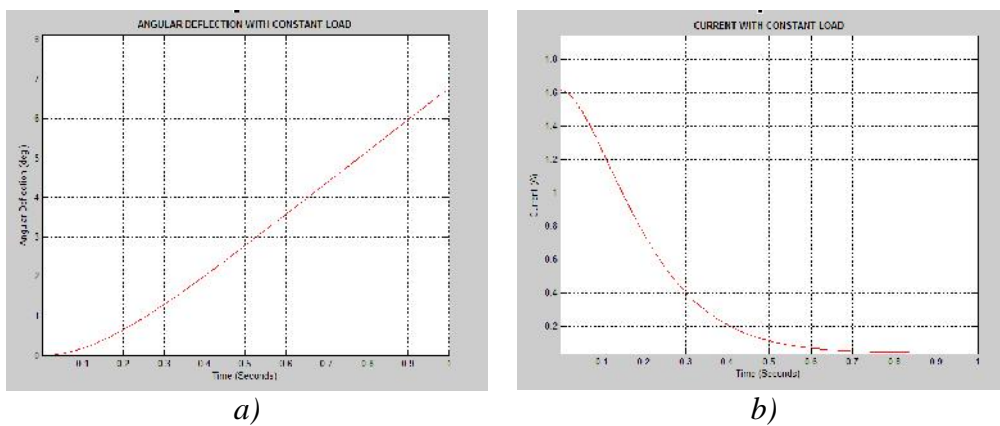

Figure 10. The results of the DC motor speed reducer simulation in the SimPower-Systems with constant load  
 a – angular deflection of the adjustment ring of the grinder  
 b – the armature current of the DC servomotor of the adjustment system

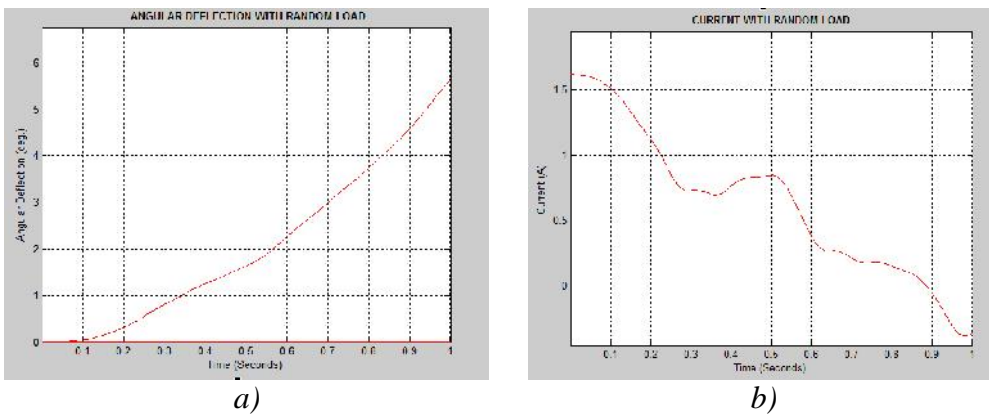

Figure 11. The results of the DC motor speed reducer simulation in the SimPower-Systems with random load  
 a – angular deflection of the adjustment ring of the grinder;  
 b – the armature current of the DC servomotor of the adjustment system.

## 5. Conclusions

As a conclusion to the present work, it can be mentioned that the automated adjustment system can provide the necessary settings and adjustments for the espresso machine so as to get the most of the coffee beans and for that the following actions have been performed:

1. Have been considered and reasoned the necessity for the adjustment system.
2. The proper possibility have been chosen and proposed.
3. A DC motor has been chosen and the speed reduced has been calculated.
4. It was proposed the possibility of using a microprocessor for the automation performance in case if it will not be possible to get a SAECO Programmer to reprogram the SAECO DIGITAL CONTROL SYSTEM.
5. A simulation has been designed and performed in order to analyze and check the chosen components; the electric motor and the speed reducer. The simulation showed that even with random load on the grinder the angular deflection within 1-2 seconds is quite enough for the adjustment process.

The designed automated adjustment system can be used as a separate intermediate device between a professional grinder and a professional coffee machine in order to provide the best quality of the coffee beverage.

## References

- [1] The Certified Italian Espresso and Cappuccino. [http://www.espressoitaliano.org/files/File/istituzionale\\_inei\\_hq\\_en.pdf](http://www.espressoitaliano.org/files/File/istituzionale_inei_hq_en.pdf)
- [2] Saeco technical support, [www.saeco.co.uk/espresso-machine-support](http://www.saeco.co.uk/espresso-machine-support)
- [3] Ulka Coffee Division General Catalog, [http://www.ceme.com/admin/moduli/m003\\_web/file/pag\\_ULKA\\_web.pdf](http://www.ceme.com/admin/moduli/m003_web/file/pag_ULKA_web.pdf)
- [4] El-Motor technical support, <http://el-moto.ru/index/0-782>
- [5] Ilie Nuca. Modelarea Matematică a Sistemelor Electromecanice, Note de curs. <http://elearning.utm.md/moodle/course/view.php?id=67>

## Addresses:

- As. Prof, Dr.Eng. Ilie Nuca, Technical University of Moldova, 31 August str., no.78, 2012, Chisinau, [nuca\\_ilie@yahoo.com](mailto:nuca_ilie@yahoo.com)
- Eng. Adrian Țurcanu, Technical University of Moldova, 31 August str., no.78, 2012, Chisinau, [adrian.em081@gmail.com](mailto:adrian.em081@gmail.com)