



TECHNICAL UNIVERSITY OF CLUJ-NAPOCA

ACTA TECHNICA NAPOCENSIS

Series: Applied Mathematics and Mechanics

Vol. 56, Issue IV, November, 2013

KINETOSTATIC ANALYSIS AND OPTIMIZATION OF PLANETARY PRECESSIONAL TRANSMISSIONS

Ion BOSTAN, Valeriu DULGHERU, Anatolie SOCHIREAN

Abstract: The paper presents the CAD (Autodesk Inventor) modeling and CAE simulation of precessional drives capable of high transmission ratio and torque for one stage compact construction. The simulations of the drives provide information concerning forces, torques and energies, as well as contact forces between gear teeth and satellite teeth. Also, there is presented the analysis of the results concerning the design optimization of the planetary precessional transmission.

Key words: precessional drives, CAD design, CAE simulation.

1. INTRODUCTION

The diversity of user requirements imposed on mechanical transmissions emphasizes the necessity of an increased the reliability and efficiency, and on the other hand a decrease in mass and dimensions of drives. It becomes more and more difficult to satisfy the above mentioned requirements by updating partially the traditional transmissions. This problem can be solved by using new types of mechanical transmissions, namely planetary precessional transmissions (PPT).

The advantages of the precessional planetary transmissions [1] include the following: • *high efficiency*, rating 96%, due to the gearing with convex-concave teeth profile; • *wide range of transmission ratio* from $\pm 8,5$ to ± 3600 in the drives with only one stage; • *high carrying capacity* achieved through up to 100% teeth coupling simultaneously; • *compactness and reduced weight* with specific weight of drives ranging from 0,022 to 0,05 kg/Nm; • *high kinematic accuracy*; • *high rating life*; • *low level of noise and vibration* ranging from 50 to 60 dB; • *low moment of inertia* due to the peculiarities of the spherical motion of the planet pinion.

The computer based engineering methods allow to develop a new type of precessional transmissions with multi-couple teeth contact, that from technological point of view can be manufactured by means of a new processing method of conical teeth with convex-concave profile.

The kinematic scheme and 3D assembly of planetary precessional transmission is presented in Fig. 1 [1,2]. Before modelling and simulation stage the basic parameters have to be computed. The main elements of the transmission are as follows: crankshaft 1 (*H*), block satellite 3 (*g*), fixed wheel gear 2 (*b*), and mobile wheel gear 4 (*a*). The advantage of the drive consists in the design possibility of obtaining a transfer ratio of up to 3600 in one stage, and consequently a double-stage design will assure a transfer ratio of the mechanism up to 14.000.000. The functioning principle [1, 2] of the planetary precessional transmission is the following: the crankshaft 1, by means of the inclined section, is bearing a block satellite 3 with spatially spherical movement; the block satellite, by means of a crown with conical rollers instead of teeth, interacts with a fixed gear 2 on one side and on the opposite side another crown with conical rollers is in contact with the gear 4. The two gears have a special tooth profile defined by means of the motion equations. The mobile gear

4 is fixed on the output shaft of reducer, transferring to it the torque moment and revolution speed. The directions of rotation of input and output shafts can be the same or opposite. One can ascertain that when calculating the transfer ratio if it is a positive number there exist identical rotations for input and output shafts.

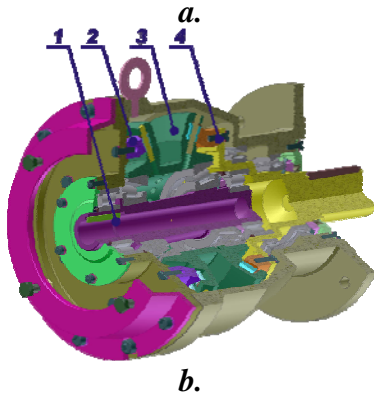
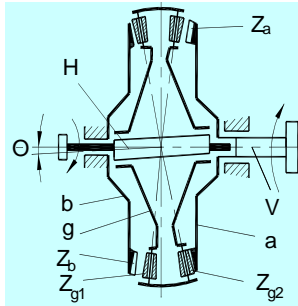

Fig. 1. Model of planetary precessional transmission: a – kinematic diagram; b – 3D assembly.

The transfer ratio of the planetary precessional transmission is defined by as follows:

$$i = -\frac{Z_{g1} Z_a}{Z_b Z_{g2} - Z_{g1} Z_a} \quad (1)$$

where: Z_{g1} , Z_{g2} are number of rollers of the satellite crowns g_1 and g_2 ; Z_a and Z_b are number of teeth of the gears a and b .

Due to the functioning principle the bearing joint of the block satellite 3 on crankshaft 1 are loaded with input rotation and output loading, respectively the load is transferred to the bearing supporting the entire part on the reducer housing.

In order to solve this problem it is necessary to use integrated methods of design, modelling

and simulation using powerful tools for creation and management of the parametrical models of mechanical assemblies on the basis of CAD-CAE platforms [4, 5].

2. ANALYSIS AND CAE OPTIMIZATION OF DYNAMIC LOADS IN PPT BEARING

2.1. Theoretical analysis of dynamic loads in PPT bearing

The analysis of dynamic loads in the bearings A , B between crankshaft and drive housing, and D , E between crankshaft and block satellite (Fig. 2) is of big importance in the case of planetary precessional transmissions. The bearings D , E (inner rings) rotate with input angular velocity and there are loaded with a complex loading (radial-axial). Therefore, in this node tapered roller bearings are being used, that have high loading capacity at small dimensions. The sizes of bearings (in particular external diameter) are imposed by the size of a gear with rollers of the block satellite. In the points A and B the roller bearings with a possibility of axial motion for auto-positioning (self finding its centre) of the block satellite between fixed and mobile gears are chosen.

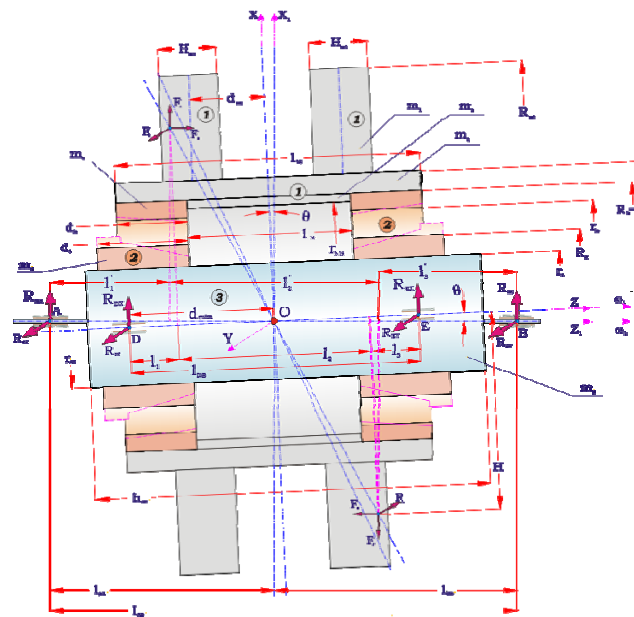

Fig. 2. Dynamic model of planetary precessional transmission.

For the theoretical computation of dynamic loads in points A , B , D , E (fig. 2) the dynamic model of motion transfer was considered [3]. According to Euler theory, the fixed frame of coordinates $OX_1Y_1Z_1$, and mobile system of coordinates $OXYZ$ rigidly connected with the block satellite 1 are located according to the scheme shown in Fig. 2. For the given example the centre of gravity is supposed to be located in point O , the precession centre.

In scheme shown in Fig. 4, all values that define the dynamic loads in the bearings of the block satellite revolving on the crankshaft in points D , E , and of crankshaft revolving on housing in points A , B are shown [2].

The static loads are determined depending on the forces in the gearing: axial force F_a , radial force F_r and a tangential force F_t , and the distances between them.

In order to quantify the dynamic loads, it is taken into consideration the fact that loads depend on the geometry of the mechanism, the motion characteristics and velocity. In this design case, an important factor is necessary to be established, namely, the upper limit of velocities at which the transmission can possibly work, in view of the present loads in the bearings.

The dynamics description of the block satellite is performed by means of Euler dynamic equations for rigid body motion around a fixed point:

$$\begin{aligned} \frac{dL_X}{dt} + \omega_{2Y}L_Z - \omega_{2Z}L_Y &= M_X^{(e)} \\ \frac{dL_Y}{dt} + \omega_{2Z}L_X - \omega_{2X}L_Z &= M_Y^{(e)} \\ \frac{dL_Z}{dt} + \omega_{2X}L_Y - \omega_{2Y}L_X &= M_Z^{(e)} \end{aligned} \quad (2)$$

where: ω_{2X} , ω_{2Y} , ω_{2Z} and L_X , L_Y , L_Z are projections of angular velocities and the linear momentums for each axis respectively, that in this case reduces to $\omega_{2X} = \omega_2 \sin \theta$; $\omega_{2Y} = 0$; $\omega_{2Z} = \omega_2 \cos \theta - \omega_1$; $L_X = I_X \omega_{2X}$; $L_Y = I_Y \omega_{2Y}$; $L_Z = I_Z \omega_{2Z}$; $M_X^{(e)}$; $M_Y^{(e)}$; $M_Z^{(e)}$ - projections of the moments of external forces on axes.

After a series of transformations, the definition relation for dynamic load in points D and E is obtained:

$$Q_D = Q_E = \frac{M_Y^{(e)}}{l_{DE}} = \frac{\omega_2 \sin \theta [I_Z \omega_1 + \omega_2 \cos \theta (I_X - I_Z)]}{l_{DE}} \quad (3)$$

where I_X and I_Z are the total moments of inertia with respect to axis X and Z respectively; ω_2 - angular velocity of the block satellite with respect to the mobile axis.

The additional dynamic loads in bearings A and B due to the dynamic unbalance of the inclined part of crankshaft are as follows:

$$\begin{aligned} Q'_{AX_1} + Q'_{BX_1} &= 0; \quad Q'_{AY_1} + Q'_{BY_1} = 0 \\ \frac{1}{2} l_{AB} Q'_{AY_1} - \frac{1}{2} l_{AB} Q'_{BY_1} &= -I_{YZ_1} \omega_2^2 \\ -\frac{1}{2} l_{AB} Q'_{AX_1} + \frac{1}{2} l_{AB} Q'_{BX_1} &= I_{XZ_1} \omega_2^2 \end{aligned} \quad (4)$$

where Q'_{AX_1} , Q'_{BX_1} , Q'_{AY_1} , Q'_{BY_1} are the projections of additional dynamic loads with respect to axes X_1 and Y_1 on inclined part of a crankshaft in points A , B ; l_{AB} - distance between respective points; I_{XZ_1} and I_{YZ_1} - the moment of centrifugal force of inertia.

Performing again some transformations, considering the axis Y_1 as the main axis of inertia of the given segment and setting $I_{YZ_1} = 0$, one obtains the following relation for the calculation of additional dynamic loads in points A and B :

$$-Q'_{AX_1} = Q'_{BX_1} = \frac{\omega_2^2}{2l_{AB}} \sin 2\theta (I_Z - I_X) \quad (5)$$

The total additional dynamic load is defined by relations:

$$\begin{aligned} Q_{AX_1} &= Q'_{AX_1} + \frac{\omega_2 \sin \theta [I_Z \omega_1 + \omega_2 \cos \theta (I_X - I_Z)]}{l_{DE}} \\ Q_{BX_1} &= Q'_{BX_1} + \frac{\omega_2 \sin \theta [I_Z \omega_1 + \omega_2 \cos \theta (I_X - I_Z)]}{l_{DE}} \end{aligned} \quad (6)$$

2.2. CAE analysis of dynamic loads in PPT bearings

It is obvious that the simplified dynamic model can not provide accurate enough results since satellite block has a specific design and

dynamic components of these parts are strongly related to the geometrical shape of the satellite block and crank shaft. To increase the precision there was decided to use new methods of computing, such as CAE methods that currently are undergoing rapid development and more frequently used in design optimization of mechanisms. Consequently, there were elaborated two dynamic CAE models.

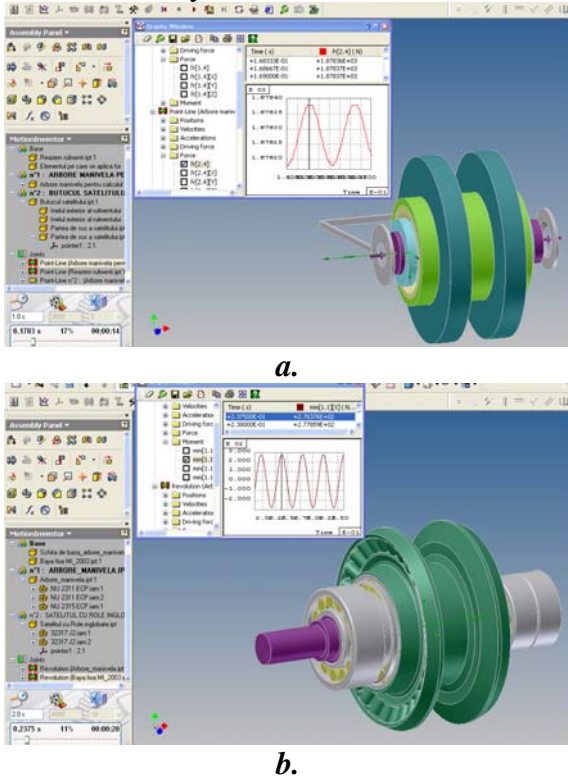

Fig. 3. Dynamic CAE model (Motion Inventor) for dynamic load analysis

The first model (Fig. 3, a) - is identical to the theoretical model shown in Fig. 2 and is being used to verify and validate the results. Thus, there was obtained a strong coincidence between the results that allowed the usage of a fully dynamic model with real geometric shape using transmission data (Fig. 3, b), rollers, bearings, etc. In the fully developed dynamic model there was performed a comprehensive analysis of the total load variations (both static and dynamic) of the satellite block bearings on the crank shaft. In Fig. 4 a, b there are shown the load variations for two gear sizes: satellite with a maximum diameter 100mm and 250mm, respectively. Totally a wide range of sizes (100mm - 500mm) and angular velocities (750 - 3000min⁻¹) were analyzed.

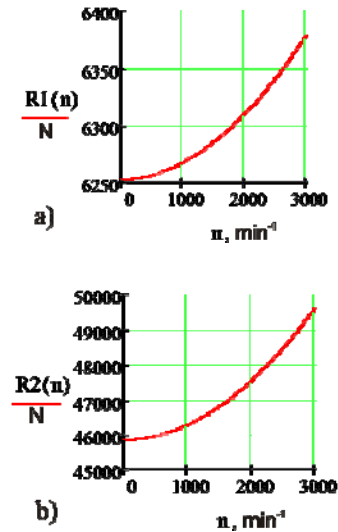

Fig. 4. Total load variations of the satellite block bearings on the crank shaft: a) D=100mm, b) D=250mm.

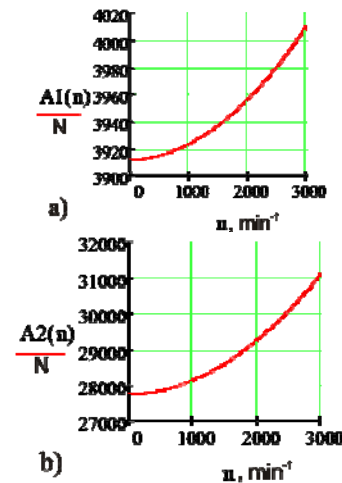

Fig. 5. Total load variations of the bearings, that support the crank shaft on the gear housing: a) D=100mm, b) D=250mm.

The analysis found (fig. 4, a) that if static reactions to this size is approx. 6252N then at the angular velocity of 3000min⁻¹ the dynamic component of the reactions is approx. 150N, representing 2.02% of the static reactions, while in the case of the satellite diameter of 250mm the increase (fig. 4, b) of the dynamic component is approx. 8.2%, that is 4 times higher and for the diameter size increased 5 times (Ø500mm) the dynamic component increase will represent approx. 40%. Taking these factors in consideration it is possible at the design stage to forecast the size of dynamic

component of the transmission corresponding to the satellite diameter.

Similar analysis was also performed on the bearings that support the crank shaft on the gear housing (Fig. 5 a, b). As previously, the influences of the satellite diameter and angular velocity on the dynamic component of the reaction forces were observed. With higher values of the diameter and angular velocity a substantial increase of dynamic reactions of these bearings are detected. It is also noted that with the increase of the diameter and angular velocity a higher increase is observed in dynamic components of the reaction forces in the bearings crankshaft - gearbox housing (growth is 52.29% compared with 40.23%). This is explained by the fact that the crankshaft, with its unbalanced construction is a generator of dynamic loads in precessional gear.

3. PPT DYNAMIC COEFFICIENT

In what follows there was determined another important parameter, namely the dynamic coefficient K_{HV} , used in dimensional analysis of the planetary precessional transmission. The importance of this coefficient can be observed from the following computational relation of the average diameter of the gearing:

$$\sigma_H = Z_M \sqrt{\frac{2T_4(1-\nu)K_{H\beta}K_{H\alpha}K_{HV}}{d_{mp}d_{m4}B_{W4}Z_\varepsilon \cos \alpha_w}} \leq [\sigma_H] \quad (7)$$

For classical transmissions the above mentioned coefficient is computed based on the static and dynamic stresses appearing in the gearing. On the other hand, for planetary precessional transmissions, the generator of the dynamic loads is the block satellite executing a sphere-spatial motion. According to fig. 6 the axial force F_a^{dyn} is determined by relation

$$F_a^{dyn} = \frac{M^{dyn}}{l_{AB}} \quad (8)$$

and respectively, the normal force acting on the teeth is given by

$$F_n^{dyn} = \frac{F_a^{dyn}}{\sin(\alpha_w)} \quad (9)$$

Based on the formula for computing of the gearing angle α_w it was determined the variation of the normal component of the dynamic forces in the precessional gearing.

In order to establish the dynamic coefficient K_{HV} a well-known relation is used:

$$K_{HV} = 1 + \frac{F_n^{dyn}}{F_n^{St}} \quad (10)$$

where: F_n^{St} - normal component of the static forces in the gearing.

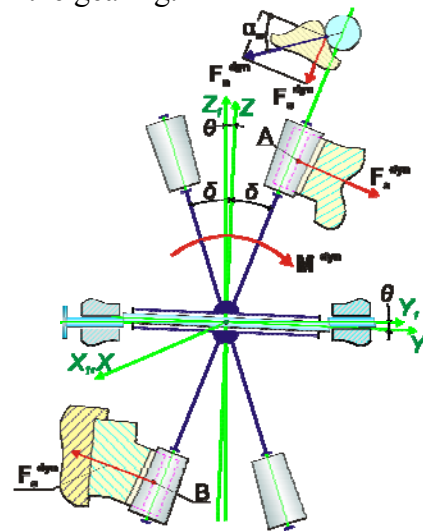

Fig. 6. Scheme for calculating the axial and normal dynamic loads.

Based on the obtained results there have been drawn the graphs of the dependence of the total dynamic torque M_Σ^d as a function of several geometric parameters of PPT. There was observed a major influence of the increase of angular velocity of the input shaft and satellite dimensions $M_\Sigma^d = f(\omega, D)$, (fig. 7).

An increase of the satellite dimensions from 100mm up to 300mm leads to an increase of the dynamic torque from 0,65Nm up to 1460Nm at the angular velocity of the crankshaft of 750min⁻¹, that constitutes an increase more than 2246 times. Similarly, for the angular velocity of 3000min⁻¹ the increase of the dynamic torque is from 10,46Nm (D=100mm) up to 23370,80Nm (D=500mm) that is 2234 times.

Dynamic coefficient K_{HV} depends especially on the main geometric parameters of PPT.

A major influence on the dynamic coefficient has the satellite diameter and the angular velocity of the leading shaft (fig. 7).

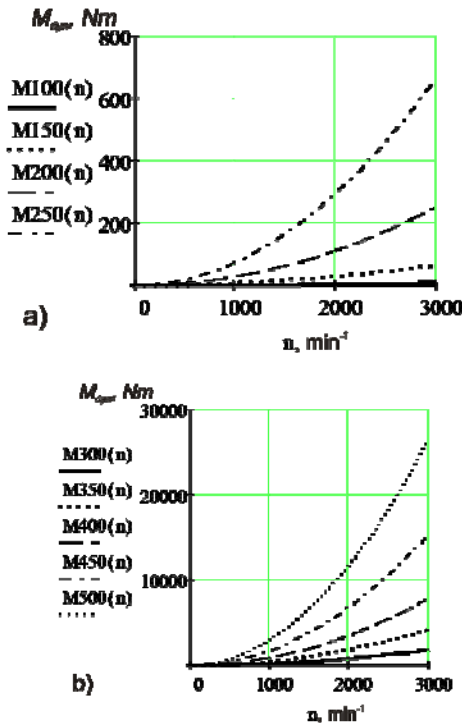

Fig. 7. Total dynamic torque as a function of the angular velocity of the input shaft n_1

From the analysis of the obtained graphs, if the maintaining the dynamic coefficient in the range of 1,1 is preferred, then the following recommendations can be concluded:

- For angular velocities up to 1000min^{-1} it is recommended to use all reducers with dimensions in the range 100...500mm.
- For angular velocities up to 1500min^{-1} it is recommended to use all reducers with dimensions in the range 100...400mm.
- For angular velocities up to 3000min^{-1} it is recommended to use all reducers with dimensions in the range 100...200mm.

Analiza cinetostatică și optimizarea transmisiilor planetare precesionale

Rezumat: Lucrarea conține analiza cinetostatică și optimizarea transmisiilor planetare cu precizie.

- Ion BOSTAN**, PhD.Dr.Sc.Prof., rector, Technical University of Moldova, Department “Fundamentals of Machine Design”, E-mail: bostan@adm.utm.md. Office Phone: 00373 22 23 78 61. Home Address: Lidia Istrati 20, Str. Home Phone: 00373 22 31 92 63.
- Valeriu DULGHERU**, PhD.Dr.Sc.Prof., Head of Department, Technical University of Moldova, Department “Fundamentals of Machine Design”, E-mail: dulgheru@mail.utm.md Office Phone: 00373 22 509939. Home Address: Lidia Istrati 23, Str. Home Phone: 00373 22 34 79 07.
- Anatolie SOCHIREAN**, PhD. Assoc.prof., Technical University of Moldova, Department “Fundamentals of Machine Design”, E-mail: salic@mail.utm.md Office Phone: 00373 22 509988. Home Address: Izmail 102/4 Str., ap.35/2, Str. Home Phone: 00373 22 27 39 72.

4. CONCLUSIONS

Results presented in this paper aim to help designers of precessional transmissions allowing a proper choice at the design stage of the dynamic load coefficient for concrete parameters of planetary precessional transmissions. Also, based on the models shown above it is possible to determine on the actual model at the stage of design the dynamic load coefficient for any configuration of reducers.

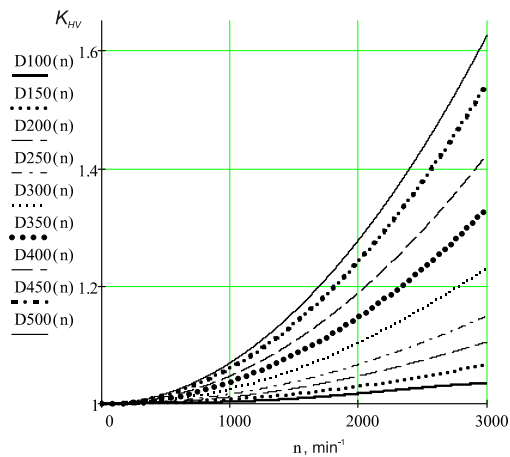

Fig. 8. Dynamic coefficient as a function of the ω and diameter of the block satellite D .

REFERENCES

1. Bostan I., *Precessionnye Peredaci s Mnogoparnym Zaczepeniem. Shtiintza*. ISBN 5-376-01005-8, Chișinău, 1991.
2. Bostan I., Dulgheru V., Grigoraș Ș., *Planetary, precessional and harmonic transmissions*, București- Chișinău, 402 p., 1997.
3. Sochirean A., *Doctor Engineer Thesis*, Technical University of Moldova, Chișinău, 2008.
4. Autodesk Inventor - www.autodesk.com.